

EZ-Pull Handle Installation Instructions

A: Close Screen door and place inside handle on door frame at desired height.

B: Slide handle toward the door jamb and mark accordingly:

- If **PLUNGER** contacts jamb first, back up 1/8" from jamb and mark the top hole. (See Fig 1)
- If handle **BODY** contacts the Z-bar first, back up 1/8" from z-bar and mark top hole. (See Fig 2)

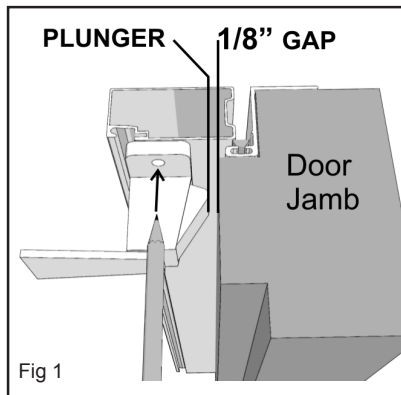

OR

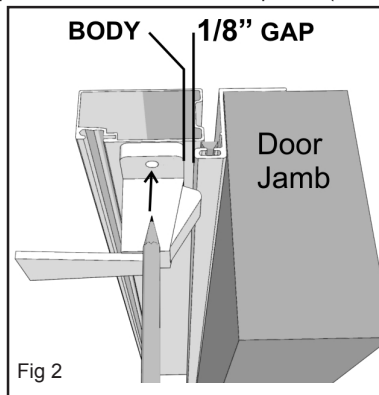

C: Open door and use the three hole template to mark the other two holes. (See Fig 3)

D: Drill three 5/16" or 1/4" holes straight through the door frame.

E: Assemble door handle components as shown.

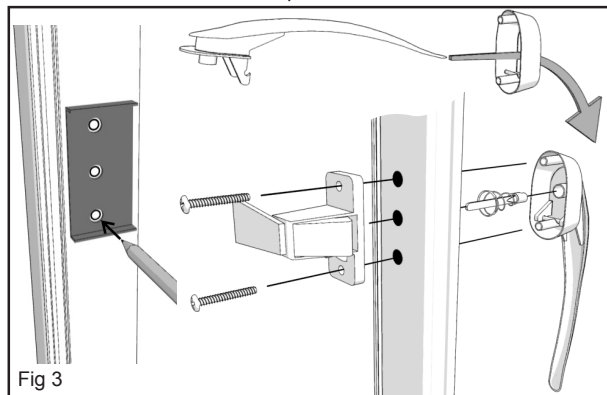

F: Install appropriate strike for adequate latching

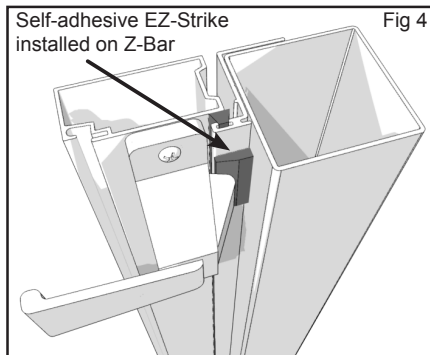

OR

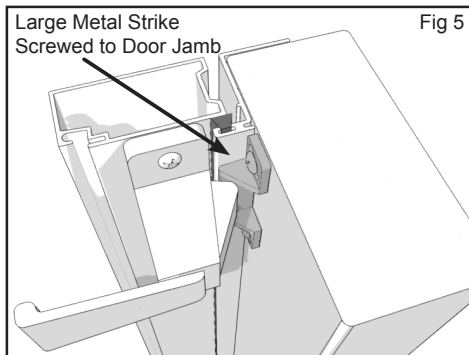

OR

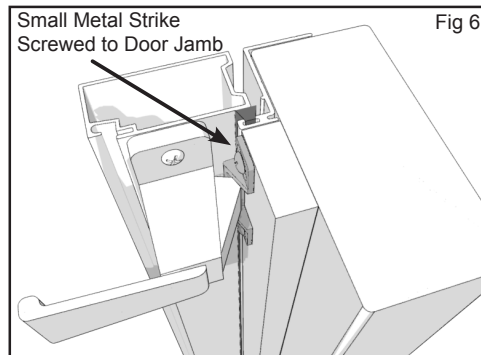

Closure Tube Installation Instructions



Step 1. Install Closure Tube

A: At desired height, mount jamb bracket

BE SURE Open side of Jamb Bracket faces door frame.

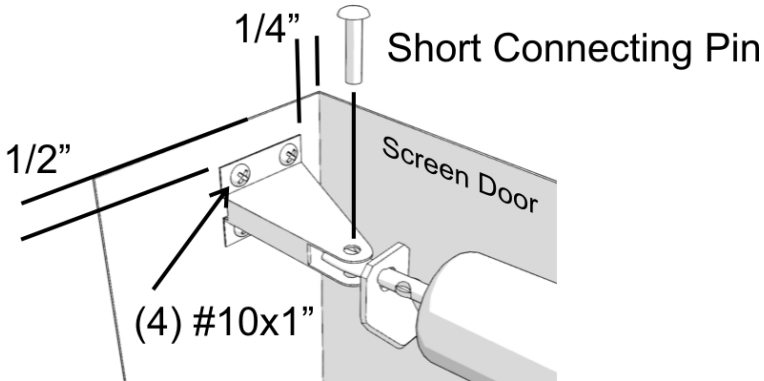

B: Pull closure tube shaft out enough to set "Hold Open Washer".

"Hold Open Washer"
Set for **bracket placement**



C1: Install door bracket as shown in front closure tube hole. Drill (2) 3/16" pilot holes for #10x1/2" screws

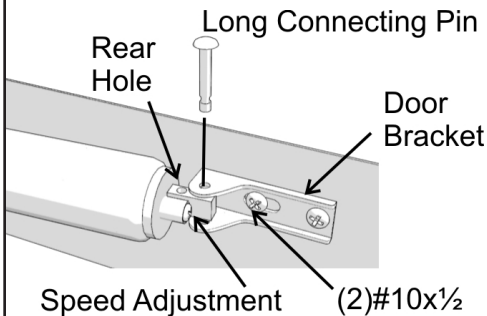

C2: After installing the door bracket, return the "Hold Open Washer" to the normal position.

"Hold Open Washer"
in **normal position**

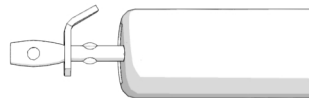

D: Closing speed can be regulated by turning the speed adjustment screw clockwise to decrease and counter clockwise to increase.

E. If less latching power is required, prop the door open slightly using the "Hold Open Washer". Pull the long pin from the door bracket and move it to the rear hole on the closure tube.