

# ALBRIGHT INSWINGING LATCH INSTALLATION INSTRUCTIONS

1. Fold on dashed line.

2. With door in closed position place this leaf of instructions on the outside of door with the fold (dashed line) against the wood stop or metal Z-bar, whichever projects farther, and mark the (3) 1/4" diameter hole centers.

3. Drill (3) 1/4" diameter holes straight through the door.

4. Unfold instructions and place on inside of door with (3) 1/4" diameter circles over the (3) holes you drilled in Step #3 and mark location of (2) strike mounting holes on door jamb.

5. Insert square spindle into the inside latch assembly and position on inside of door. Install outside latch assembly and secure with (2) machine screws. If the spindle binds enlarge center hole.

6. Attach strike to wood jamb with Sheet Metal Screws.

NOTE: If latch kit contains key cylinder option use KEY CYLINDER INSTALLATION INSTRUCTIONS included with key cylinder assembly.

83743, REV A

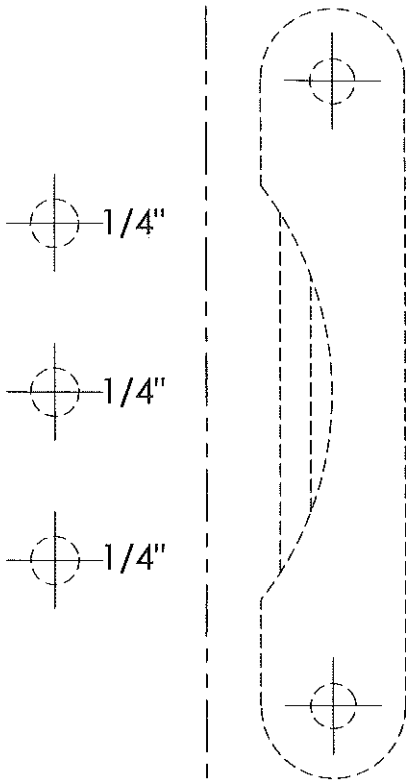



# In-Swing Closure Bracket Installation Instructions

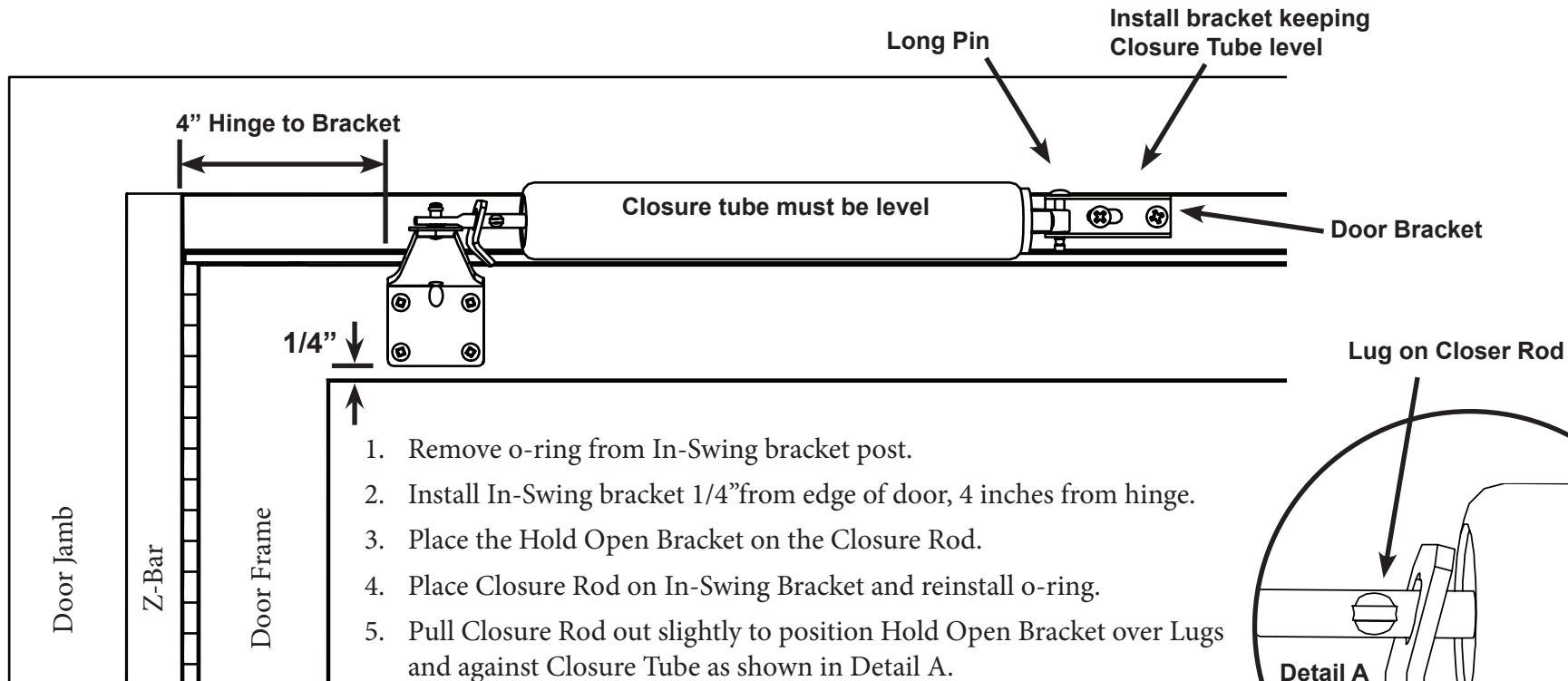

1. Remove o-ring from In-Swing bracket post.
2. Install In-Swing bracket 1/4" from edge of door, 4 inches from hinge.
3. Place the Hold Open Bracket on the Closure Rod.
4. Place Closure Rod on In-Swing Bracket and reinstall o-ring.
5. Pull Closure Rod out slightly to position Hold Open Bracket over Lugs and against Closure Tube as shown in Detail A.
6. With door closed tightly, attach Door Bracket to front hole in Closure with Long Connecting Pin. Hold bracket so Closure Tube is level and fasten with two short screws.
7. Open door and move Hold Open Bracket back to it's normal position. Closure speed can be adjusted by turning adjusting screw on end of Closure Tube.

